

〈Regular Article〉

Simple and rapid detection method for *qepA1* by loop-mediated isothermal amplification

Kunikazu YAMANE^{1, 2, 3)}, Atsuko HORINO²⁾, Satowa SUZUKI²⁾,
Keigo SHIBAYAMA²⁾, Shigeko FUSHIMI¹⁾, Hironobu KATSUYAMA¹⁾

1) Department of Public Health, Kawasaki Medical School,
577 Matsushima, Kurashiki, Okayama, Japan 701-0192

2) Department of Bacteriology II, National Institute of Infectious Diseases,
4-7-1 Gakuen, Musashi-Murayama, Tokyo, Japan 208-0011

3) Department of Infectious Diseases, Yonago Medical Center, National Hospital Organization,
4-17-1 Kuzumo, Yonago, Tottori, Japan 683-0006

ABSTRACT Although fluoroquinolone (FQ) has been used for the treatment of various bacterial infectious diseases, its continued use has been problematic given the appearance of FQ-resistant bacteria. However, the recent discovery of four plasmid-mediated quinolone resistance (PMQR) genes comprising *qnr*¹⁾, *aac(6')Ib-cr*²⁾, *qepA*³⁾ and *OqxAB*⁴⁾ since 1998⁵⁾ has provided insights in the area of FQ-resistance. For practical detection of *qepA* in microbiology laboratory, a specific, simple, rapid and cost-effective isothermal amplification method designated as LAMP is the good candidate to use. In this study, the development of a new detection method using LAMP to identify *qepA1*, one variant of the *qepA* gene, was tried. As the results, the LAMP method using a *qepA1*-specific LAMP primer set comprising five primers could detect all four *qepA1*-positive strains in addition to 17 *qepA1*-negative strains. The LAMP method is clearly much more advantageous for use in clinical laboratories. Furthermore, the time and accuracy benefits allow for the selection of antibiotics in a clinical setting.

doi:10.11482/KMJ-E42(1)25 (Accepted on Jun 6, 2016)

Key words : *QepA1*, Plasmid-mediated Quinolone Resistance, LAMP

INTRODUCTION

Although fluoroquinolone (FQ) has been used for the treatment of various bacterial infectious diseases, its continued use has been problematic given the appearance of FQ-resistant bacteria. The bacterial genes targeted by FQ are DNA gyrase,

comprising the two genes *gyrA* and *gyrB*, and DNA topoisomerase IV, formed by the two genes *parC* and *pare*. FQ-resistance mainly results from genetic mutations in the quinolone resistance-determining region (QRDR) located within the DNA topoisomerase gene of bacteria.

Corresponding author
Kunikazu Yamane
Department of Infectious Diseases, Yonago Medical
Center, National Hospital Organization, 4-17-1
Kuzumo, Yonago, Tottori, Japan 683-0006

Phone : 81 859 33 7111
Fax : 81 859 34 1580
E-mail: yamane-kunikazu@nho-yonago.jp

However, the recent discovery of four plasmid-mediated quinolone resistance (PMQR) genes comprising *qnr*¹⁾, *aac(6')Ib-cr*²⁾, *qepA*³⁾ and *OqxAB*⁴⁾ since 1998⁵⁾ has provided insights in the area of FQ-resistance. Of these four PMQR genes, *qepA* encodes a major facilitator superfamily (MFS)-type efflux pump which imparts resistance against hydrophilic FQs such as ciprofloxacin, norfloxacin and enrofloxacin. Additionally, there are two variants of the *qepA* gene designated *qepA1* and *qepA2*, and are referred to as the major and minor variants, respectively. There is only a two-amino acid difference between these variants, and both variants were identified from *Escherichia coli*^{3, 6)}.

Although the contribution of mutations in PMQR genes towards FQ-resistance is relatively low, changes to PMQR genes may contribute towards the genetic mutation of QRDRs⁷⁾, such as the acquisition of additional mutations. Thus, the ability to determine whether clinically isolated bacteria possess mutations in *qepA* in the microbiology laboratory is very important. Although molecular

methods such as PCR or real-time PCR have been employed to detect mutations in the *qepA* gene^{8, 9)}, these methods require specialized equipment. To overcome this limitation, the loop-mediated isothermal amplification (LAMP) method was developed. LAMP comprises a strand displacement reaction using four different primers specifically designed to recognize six distinct regions on the target gene at a constant temperature^{10, 11)}.

Briefly, LAMP is a specific, simple, rapid and cost-effective isothermal amplification method. LAMP employs *Bacillus stearothermophilus* (*Bst*) I DNA polymerase, and relies on auto-cycling strand DNA synthesis performed at 60-65°C for 45-60 min. Since its development, LAMP has been widely used to detect various microorganisms, such as dengue virus, West Nile virus, and others. A schematic showing the construction of LAMP primers is shown in Fig. 1. Details of amplifications can be seen in previous report¹¹⁾.

In this study, the development of a new detection method using LAMP to identify *qepA1*, one variant

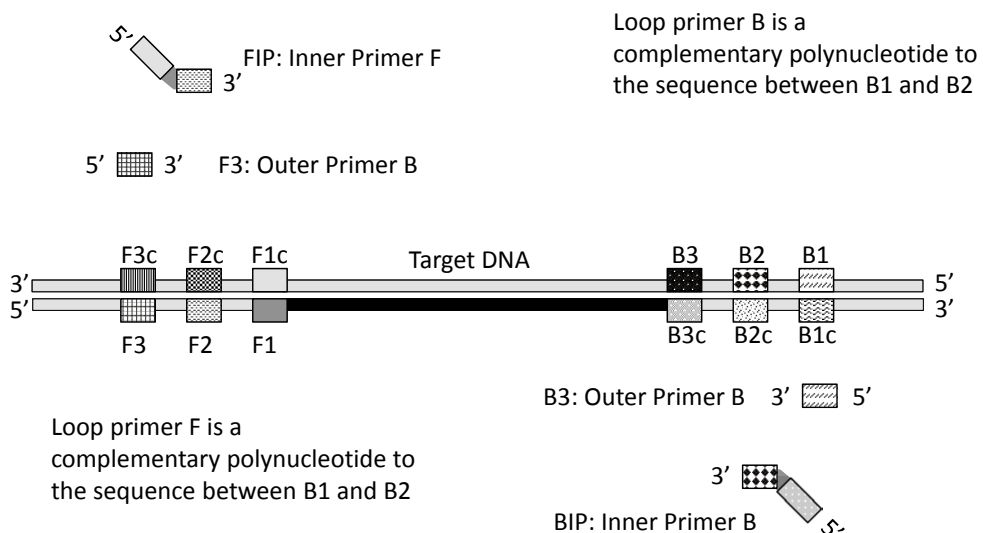

Fig. 1. Schematic presentation of LAMP primer sets including forward and backward inner, outer and loop primers around target DNA (modified from a Figure in reference #11).

of the *qepA* gene, is described.

MATERIALS AND METHODS

The bacterial strains used in this study are listed in Table 1. For LAMP to detect *epA1*, five LAMP primers were designed as shown in Table 2 by using the software “Primer Explore version 3” (now, it is upgraded to version 4; <http://primerexplorer.jp/e/>). Genomic DNA from bacterial strains and plasmid for the *qepA1* positive control (pSTV*qepA*) were extracted using the Qiagen genomic tip 20/G (Qiagen, Tokyo, Japan) and a Wizard plus minipreps DNA purification system (Promega, Tokyo, Japan), respectively. The LAMP reaction was performed using the Loopamp DNA amplification kit (Eiken Chemical Co. Ltd., Tokyo, Japan), according to the manufacturer’s instructions. A 25 μ l reaction mixture containing 40 pmol of QEP-FIP (forward

inner primer) and QEP-BIP (backward inner primer) primers, 10 pmol of QEP-F3 (forward outer primer) and QEP-B3 (backward outer primer) primers, 20 pmol of QEP-LF (forward loop primer), 2 x reaction mixture (25 μ l), *Bst* DNA polymerase (1 μ l), and 5 μ l of template DNA were used for LAMP amplification. The difference of this reaction compared with Fig. 1 was no usage of BIP (as shown in Fig. 1) primer for enhancement of PCR efficacy, because of no adequate sequence in the target gene.

In an effort to determine the lowest detection limit of template copy number within the reaction, DNA derived from template plasmid pSTV*qepA* was employed in the LAMP method with 0.5 to 500 copies (10-fold dilutions) in the reaction. LAMP amplification was confirmed by monitoring the increase in turbidity using LA-320C (Eiken

Table 1. Strains used in this study and results obtained by the LAMP method

Type of gene*	Strain	Result
<i>qepA1</i>	<i>Escherichia coli</i> C316	+
	<i>Escherichia coli</i> MRY04-1060	+
	<i>Escherichia coli</i> MRY07-551	+
	<i>Escherichia coli</i> MRY06-100	+
<i>qnrA</i> type	<i>Enterobacter cloacae</i> MRY04-769	–
	<i>Enterobacter cloacae</i> MRY04-1155	–
	<i>Escherichia coli</i> ARS66	–
<i>qnrB</i> type	<i>Klebsiella oxytoca</i> MRY04-725	–
	<i>Enterobacter cloacae</i> MRY04-269	–
	<i>Enterobacter cloacae</i> MRY04-634	–
	<i>Escherichia coli</i> MRY17-739, EE36	–
	<i>Escherichia coli</i> EE36	–
<i>qnrS</i> type	<i>Klebsiella pneumoniae</i> MRY05-548	–
	<i>Klebsiella pneumoniae</i> MRY05-478	–
	<i>Enterobacter cloacae</i> MRY04-1272	–
	<i>Klebsiella pneumoniae</i> NCB03-81, MRY05-2	–
<i>aac(6')Ib-cr</i>	<i>Klebsiella pneumoniae</i> MRY05-2	–
	<i>Escherichia coli</i> MRY05-244	–
	<i>Escherichia coli</i> MRY07-128	–
	<i>Klebsiella pneumoniae</i> MRY05-512	–
	<i>Klebsiella pneumoniae</i> MRY09-945	–

*Each genotype was characterized by PCR.

Table 2. LAMP primers utilized for the detection of *qepA1*

Primer	Sequence (5'-3')
QEP-F3	TGCCGTGCCTGGTCTAC
QEP-B3	AGGCGAATGCGAAGAACG
QEP-FIP	GAGAAGCTGGGCGCTGGAGGGACCTCACGGTGTGAAC
QEP-BIP	CGTCGCCGGCTTCCTGATCCGCGCCGATCAACAAC
QEP-LF	TTCACGGCTGAGCACCG

Chemical Co. Ltd.), and amplified products were analyzed by electrophoresis through 2% agarose gels followed by ethidium bromide staining. In addition to electrophoretic detection, direct visualization of *qepA1*-positives in PMQR-positive strains (shown in Table 1) was performed by visual judgment using Loopamp fluorescent detection reagent (Eiken Chemical Co. Ltd.), according to the manufacturer's instructions.

RESULTS

The LAMP method was performed at 63°C within one hour. This represents less than half the time required for standard PCR methods. Thereafter, the lowest detection level of *qepA1* using this method was five copies of plasmid.

The LAMP method using a *qepA1*-specific LAMP primer set comprising five primers could detect all four *qepA1*-positive strains in addition to 17 *qepA1*-negative strains (Table 1).

DISCUSSION

In this study, we introduced a quick and easier detection method for the special *qepA1* sequence in bacterial genomes using the LAMP method in combination with *qepA1*-targeted primer sets developed for this method. Our LAMP-based approach could detect *qepA1*-positive model strains, derived from PMQR gene-positive gram-negative rod characterized by a standard PCR method, with 100% sensitivity and specificity. Although the LAMP method requires DNA extraction, the total detection time is shorter than standard real-time PCR. From our experiments, the application time was approximately one hour (plus time for DNA extraction), and represents less than half the time required for standard PCR or real-time PCR. Additionally, since standard PCR and real-time PCR methods require special instrumentation, as well as special primer sets⁸⁻¹¹⁾, the ultimate objective is to have available a simple, quick and

accurate detection system that can be employed for routine examinations in clinical laboratories to detect *qepA1* in clinically isolated bacteria. Thus, once the instrument and primer sets have been determined, factors such as time and accuracy need to be considered. From this standpoint, the LAMP method is clearly much more advantageous for use in clinical laboratories. Furthermore, the time and accuracy benefits allow for the selection of antibiotics in a clinical setting.

Although we should set most of the antibiotic-resistant genes for clinical use, a better approach would be to strongly recommend use of the LAMP method for the detection of these genes to provide better support for the clinical selection of antibiotics to combat infections.

ACKNOWLEDGMENTS

This study was supported by a grant (H24-Shinkou-Ippan-010) from the Ministry of Health, Labour and Welfare, Japan and a Research Project Grant 24B-85 from Kawasaki Medical School.

REFERENCES

- 1) Tran JH, Jacoby GA: Mechanism of plasmid-mediated quinolone resistance. *Proc Natl Acad Sci USA* 99: 5638-5642, 2002
- 2) Robicsek A, Strahilevitz J, Jacoby GA, Macielag M, Abbanat D, Park CH, Bush K, Hooper DC: Fluoroquinolone-modifying enzyme: a new adaptation of a common aminoglycoside acetyltransferase. *Nat Med* 12: 83-88, 2006
- 3) Yamane K, Wachino J, Suzuki S, Kimura K, Shibata N, Kato H, Shibayama K, Konda T, Arakawa Y: New plasmid-mediated fluoroquinolone efflux pump, QepA, found in an *Escherichia coli* clinical isolate. *Antimicrob Agents Chemother* 51: 3354-3360, 2007
- 4) Hansen LH, Johannesen E, Burmolle M, Sørensen AH, Sørensen SJ: Plasmid-encoded multidrug efflux pump conferring resistance to olaquinox in *Escherichia coli*. *Antimicrob Agents Chemother* 48: 3332-3337, 2004
- 5) Martinez-Martinez L, Pascual A, Jacoby GA: Quinolone resistance from a transferable plasmid. *Lancet* 351: 797-

- 799, 1998.
- 6) Cattoir V, Poirel L, Nordmann P: Plasmid-mediated quinolone resistance pump QepA2 in an *Escherichia coli* isolate from France. *Antimicrob Agents Chemother* 52: 3801-3804, 2008
 - 7) Poirel L, Cattoir V, Nordmann P: Is plasmid-mediated quinolone resistance a clinically significant problem? *Clin Microbiol Infect* 14: 295-297, 2008
 - 8) Yamane K, Wachino J, Suzuki S, Arakawa Y: Plasmid-mediated qepA gene among *Escherichia coli* clinical isolates from Japan. *Antimicrob Agents Chemother* 52: 1564-1566, 2008
 - 9) Guillard T, Moret H, Brasme L, Carlier A, Vernet-Garnier V, Cambau E, de Champs C: Rapid detection of qnr and qepA plasmid-mediated quinolone resistance genes using real-time PCR. *Diagn Microbiol Infect Dis* 70: 253-259, 2011
 - 10) Notomi T, Okayama H, Masubuchi H, Yonekawa T, Watanabe K, Amino N, Hase T: Loop-mediated isothermal amplification of DNA. *Nucleic Acids Res* 28 : E63, 2000
 - 11) Hirayama H, Kageyama S, Moriyasu S, Sawai K, Minamihashi A: Embryo sexing and sex chromosomal chimerism analysis by loop-mediated isothermal amplification in cattle and water buffaloes. *J Reprod Dev*. 59: 321-326, 2013

